

### METAL PANEL APPLICATIONS

**Note:** Additional support columns and pipe hangers may be required for larger canopies and/or higher wind loads.

#### STEP 1: Install Vertical Support Columns

**Note:** Install vertical support columns to girt framing. (Girt spacing max 6'0")

**1.a**—Center canopy over door. If necessary, shift canopy toward door knob so that pipe hangers penetrate in the high or low areas of panel. When the canopy is positioned at the desired location match drill 11/16" holes through pre-drilled canopy angle holes. (These holes are aligned with the center of the zee rafter holes used for the pipe hangers at the wall attachment angle of the canopy.)

**1.b**—Align centerline of support columns with 11/16" holes drilled in step 1.a centerline of zee rafters on canopy between girts. Make sure support columns are perpendicular to top and bottom girt. Attach mounting clips to each end of telescoping support columns with (4) #12 SDS per clip. Slide adjust columns to proper length in order to fit between girts (6' maximum). Secure columns to girts with (4) #12 SDS per clip. Install (2) #12 SDS in the web and (1) in each flange at top and bottom of overlap in channels.

#### STEP 2: Install Lower Support Bolts

**2.a**—Match drill through previously drilled holes in wall panel through centerline of support columns.

**2.b**—With canopy repositioned and matching holes in canopy and wall panel aligned, attach canopy to wall panel and support column using 5/8" x 7" bolt with washer. (If hole penetrates the high rib of the panel, use PVC spacer between wall panel and support column.) **Note:** Before tightening bolts, apply sealant at penetration points.

#### STEP 3: Attach Pipe Hangers to Canopy

**3.a**—Thread 5/8" nut on the short rod end, slide on 5/8" washer and insert into hole on top of canopy rafter. Secure with 5/8" nuts and washers on underside of rafter. (Typical for each pipe hanger.)

#### STEP 4: Attach Pipe Hangers to Wall

**4.a**—Locate the elevation at the point where long rod end will penetrate the wall. Drill 11/16" hole through panel and support columns. Thread 5/8" nut on long rod end and slide on 5/8" washer. Insert long rod through wall panel and support columns. Secure at support column with 5/8" nuts and washers. **Note:** Before tightening bolts, apply sealant at penetration points.

#### STEP 5: Adjust Pitch of Canopy

**5.a**—Adjust pipe hanger yoke ends, and/or short rod end at rafter, so the canopy slopes back toward wall 1/2" to 1" (for rear mounted drains).

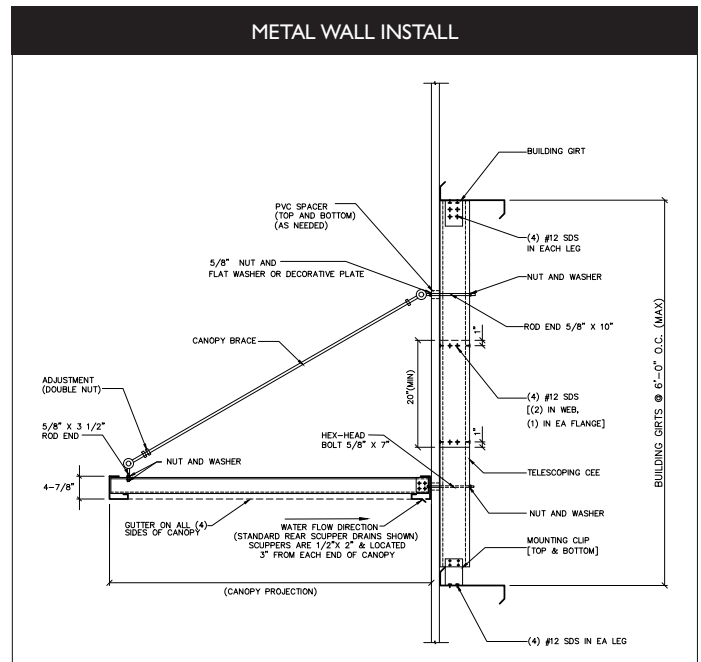
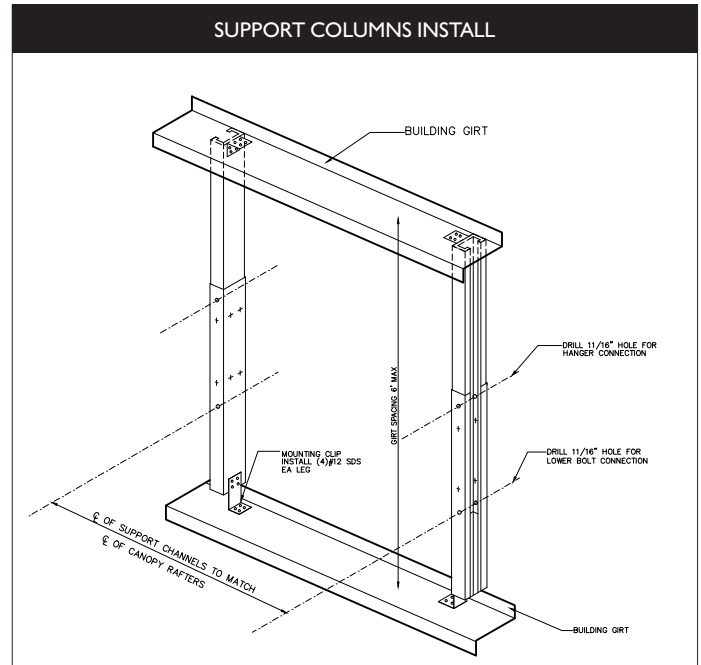
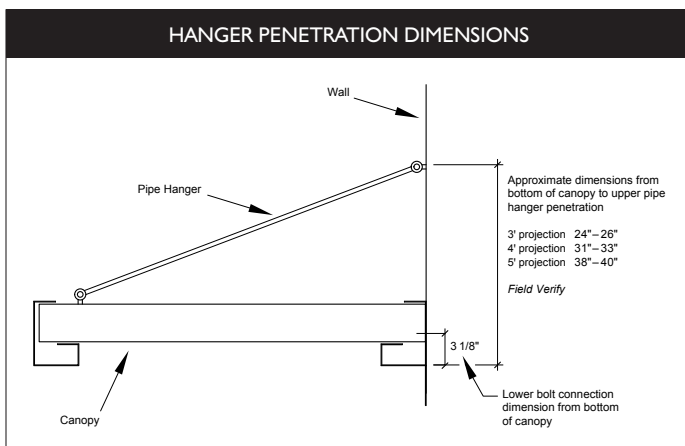

#### Metal Wall Install:

- |                               |                        |
|-------------------------------|------------------------|
| (One hardware kit per hanger) | (24) #12 X 3/4" Screws |
| (1) Pipe Hanger               | (1) 7" X 5/8" Hex Bolt |
| (1) 3-1/2" X 5/8" Rod End     | (5) 5/8" Nuts          |
| (1) 10" X 5/8" Rod End        | (6) 5/8" Washers       |
| (1) 2pc Telescoping Channel   | (2) PVC Spacers        |
| (2) 12ga Channel Clips        |                        |

### MASONRY APPLICATIONS

**Note:** Additional pipe hangers may be required for larger canopies and/or higher wind loads.

#### STEP 1: Install Lower Support Bolts

**1.a** – Center canopy over door. Mark well at locations where pre-attached canopy rafter angle holes meet wall.

**1.b** – Drill holes in masonry and install wall anchors sized to accept 5/8" bolts and appropriate design for masonry type.

**Note:** Wall anchors by others.

**1.c** – Insert 5/8" x 3" bolt with washer through canopy angle and into wall anchor.

#### STEP 2: Attach Pipe Hangers to Canopy

**2.a** – Thread 5/8" nut on one end of the pipe hanger rod end, slide on 5/8" washer and insert into hole on top of canopy rafter.

**2.b** – Secure with 5/8" nuts and washers on underside of rafter.

#### STEP 3: Attach Pipe Hangers to Wall

**3.a** – Locate elevation at the point where opposite rod end will penetrate the wall.

**3.b** – Drill holes in masonry and install wall anchors sized to accept 5/8" bolts and appropriate design for masonry. **Note:** Wall anchors by others.

**3.c** – Insert 5/8" x 3.5" thread rod end into wall anchor.

**3.d** – Attach rod end to pipe hanger with clevis pin.

#### STEP 4: Adjust Pitch of Canopy

**4.a** – Adjust pipe hanger yoke ends, and/or short rod end at rafter, so the canopy slopes back toward wall 1/2" to 1" (for rear mounted drains).

#### Masonry Wall Install:

- |                               |                        |
|-------------------------------|------------------------|
| (One hardware kit per hanger) | (1) 3" X 5/8" Hex Bolt |
| (1) Pipe Hanger               | (4) 5/8" Nuts          |
| (2) 3-1/2" X 5/8" Rod Ends    | (4) 5/8" Washers       |

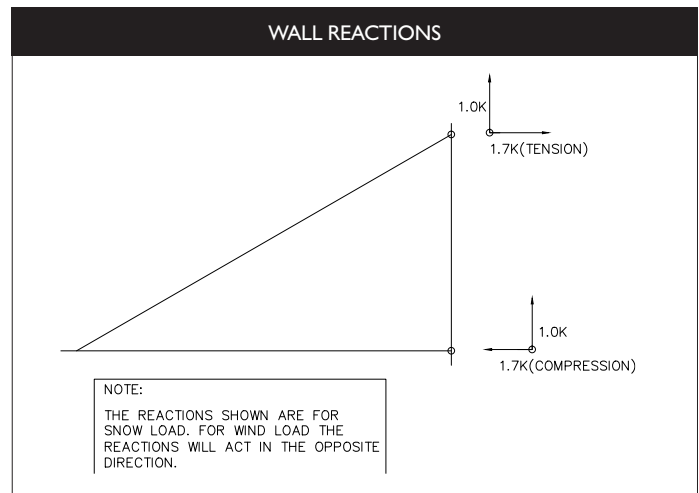
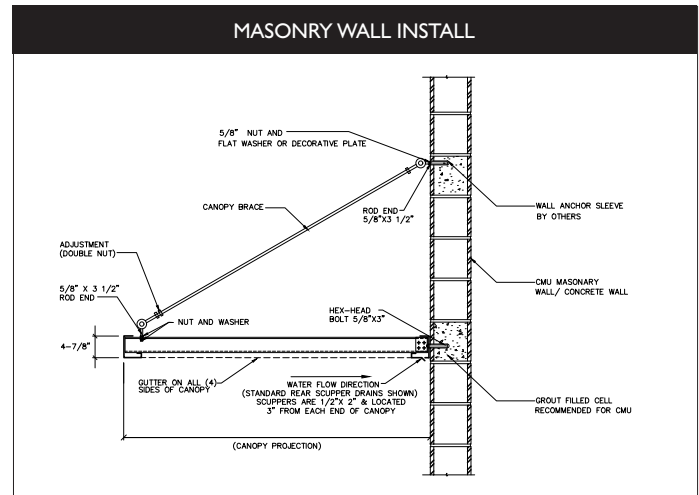

### MULTIPLE CANOPY INSTALLATION

